

Wingtip Devices: What They Do and How They Do It

Doug McLean
Boeing – Aerodynamics

1. Introduction

The idea of a beneficial wingtip appendage, or “wingtip device,” has been around since the early 20th century, when theoretical calculations first indicated that a vertical endplate added to a wingtip would reduce the induced drag. Early on, however, reality did not live up to the theoretical promise. The simple flat endplate turned out to be a disappointment in practice because the added viscous profile drag more than offsets the saving in induced drag, and the device fails to produce a net benefit. Whitcomb (ref. 1) seems to have been the first to recognize that it is possible to reap the induced-drag benefit of an endplate, and at the same time to realize a net benefit, by keeping the additional profile drag to a minimum through good aerodynamic design practice. The direct result of Whitcomb’s work is the classic near-vertical winglet. Less directly, Whitcomb’s paradigm of applying good design practice to keep the profile drag low has also contributed to the development of concepts other than the winglet. Both winglets and tapered horizontal span extensions have been put into commercial service, and several other device concepts have also been proposed and brought to varying levels of development (fig. 1.1).

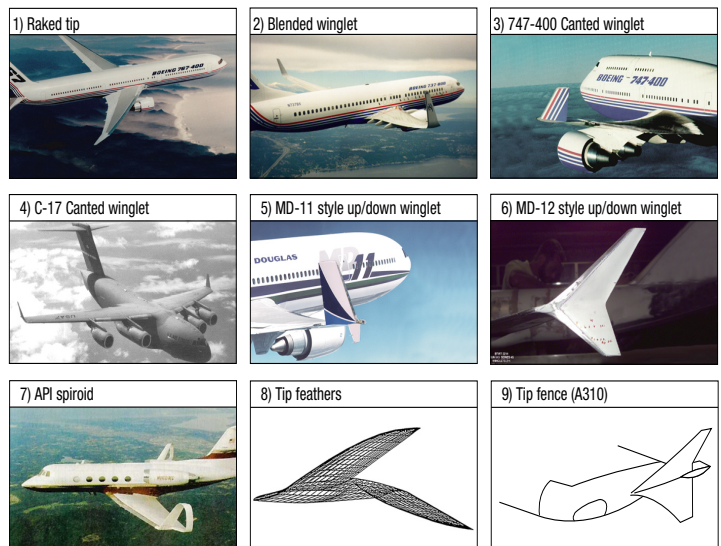

Figure 1.1. An assortment of wingtip device configurations

In this paper we discuss the benefits of wingtip devices to the operator of an airplane and attempt to provide an accessible explanation of the physics underlying those benefits. We also discuss some of the issues that affect design decisions and look at the level of benefit that has been achieved in one particular application, the API winglet on the 737NG.

2. The Benefits of Wingtip Devices

From an aerodynamicist's point of view, the motivation behind all wingtip devices is to reduce induced drag. Beyond that, as Whitcomb showed, the designer's job is to configure the device so as to minimize the offsetting penalties, so that a net performance improvement is realized. For any particular airplane and tip device, the performance-improvement can be measured relative to the same airplane with no tip device. The positive factors and offsetting factors that contribute to the performance improvement can be listed as follows:

Positive factors:

- Induced drag is reduced at takeoff and cruise.
- Shock drag is sometimes reduced a little at cruise due to the change in spanload produced by the device.

Offsetting factors:

- Profile drag is increased due to:
 - Increased wetted area.
 - Junction flows, high sectional loadings, etc.
- Weight is increased due to:
 - The weight of the device itself.
 - The weight of attachment fittings.
 - Increases in the weight of the existing wing structure due to increases in static loads and to meet flutter and fatigue requirements.

A net performance improvement is satisfying to an engineer, but for an airplane manufacturer or operator the objective is to realize the kind of bottom-line benefits that translate into dollars. Here is a list of the potential bottom-line benefits of tip devices, in rough order of importance, and some offsetting factors:

Benefits:

- Improved performance:
 - Reduced fuel burn.
 - Increased maximum range.
 - Reduced takeoff field length due to improved second segment climb.
 - Increased cruise altitude due to improved buffet boundary.
 - Increased cruise speed due to modest increase in MDD
 - Reduced takeoff noise.
- Meet gate clearance with minimal performance penalty.
- Appearance and product differentiation.

Offsetting factors:

- Increased cost (development, recurring, and purchase).
- Increased development risk.

Another possible benefit that has sometimes been put forward is that tip devices can reduce the strength of the vortex wake, with the implication that this could lead to improved safety or reduced separation distances on landing approach or takeoff. This one is not included on our list because the reduction in vortex strength is typically very small, and the resulting benefit is insignificant.

The main positive factor that makes the benefits possible is the reduction of induced drag. In the next section we discuss the physics of induced-drag reduction and its implications for the configuration of effective wingtip devices.

3. The Physics of Induced-Drag Reduction

What is induced drag?

Let's first put induced drag in perspective by looking at drag in general. Drag is just the flight-direction component of the total aerodynamic force, excluding engine thrust. (For purposes of this discussion, we'll assume drag and thrust can be cleanly separated, ignoring some serious theoretical difficulties.) The air acting on each local element of the airplane's external surface makes a contribution to the force that can be resolved into a component parallel to the local surface (shear force) and a component perpendicular to the surface (pressure force). When these two components are resolved in the flight direction and integrated over the entire external surface, the resulting forces are generally referred to as the "skin-friction" drag and the pressure drag. The skin-friction drag is entirely a result of viscous effects (viscosity and turbulence) in the boundary layers on the airplane's surfaces. The pressure drag is a result of a more complicated combination of flow mechanisms, including viscous effects, shocks, and the global effects of lift. Given enough data defining the distribution of forces on the surface, resolving the drag into a skin-friction part and a pressure part is straightforward, since it involves simply resolving a vector into components. Dividing the drag into viscous drag, shock drag, and induced drag according to the mechanisms responsible isn't so simple.

We'd like to define induced drag as the part of the drag due to the global effects of lift. We've already seen that the global effects of lift contribute to the pressure drag, but that the total pressure drag also contains contributions from other flow mechanisms. How do we define how much of the pressure drag is induced drag? There is nothing about the distribution of the forces exerted on the surface that will tell us how much of the drag was caused by which flow mechanism. And it turns out that looking at the flowfield doesn't yield a rigorous definition either. Because the different flow mechanisms overlap and interact, their effects do not add in a simple linear way to the total pressure drag, and an exact decomposition of the pressure drag into component parts is not possible. However, for practical purposes, it is possible to make an approximate decomposition, based on idealized, approximate theories regarding what goes on in the flowfield. For example, if the flow in the neighborhood of a shock is known, the shock's contribution to the drag can be estimated based on the Oswatitsch formula. Likewise, if the spanwise distribution of lift is known on the lifting surfaces, the induced drag can be estimated using Trefftz-plane theory, which is based on an idealized model of the flowfield associated with the given spanloading. So we must keep in mind that the idea that drag can be decomposed into different "components," according to the flow mechanisms responsible, is an idealization. It is a useful one, however, and in practice, predictions of drag increments based on these idealized models have proved to be reasonably accurate.

Now let's look at how the induced drag is distinguished from the other pressure-drag components, physically speaking. All forms of drag manifest themselves in the flowfield in two main ways. First, conservation of momentum requires that the drag force alters the balance of momentum and pressure. Second, conservation of energy requires that the work done against the drag force shows up as an increase in the combined heat energy and kinetic energy. (Note that while both of these relationships can be correctly expressed in any reference frame, the work/energy relationship is most clearly understood in a reference frame fixed to the air mass rather than the airplane, since that is the frame in which the work done relates most directly to the energy expended by the propulsion system.) With viscous drag and shock drag, the dissipation of energy into heat is immediate, and very little kinetic energy is involved. Induced drag is unique in that nearly all of the energy added to the flow shows up initially as kinetic energy and is dissipated into heat only very gradually over a long distance downstream.

The kinetic energy produced by induced drag is associated with a large-scale air motion caused by lift forces, mostly on the wing. In general terms, the motion is mostly perpendicular to the direction of flight and is characterized by downward flow in the area between the wingtips and upward flow outboard of the tips, as shown in Figure 3.1. Note that these lift-induced velocities are not concentrated closely just around the wing itself or the wingtips, but are spread fairly diffusely over a wide area of the flowfield.

While the air more than about one wingspan ahead of the wing is essentially undisturbed, the general flow pattern of Figure 3.1 reaches practically full strength at a distance of about one wingspan behind the wing and generally persists over long distances downstream. At the location of the wing itself, the flow pattern has reached roughly half of its maximum strength, and the wing is flying through air that is already moving generally downward between the wingtips. Thus the wing can be thought of as flying in a downdraft of its own making. Because of the apparent downdraft, or "downwash," the total apparent lift vector is tilted backward slightly. It is the backward component of the apparent lift that is felt as induced drag. When we look at the force/momentum balance, the induced drag shows up in the flowfield primarily as reduced pressure downstream of the wing.

The vortex wake

A distinctive feature of the wing-induced flowfield that is prominent in discussions of induced drag, and that plays a role in the quantitative theory, is the trailing vortex wake. The nature of the vortex wake and its role in induced drag have been a source of some serious misunderstandings, and these erroneous ideas have resulted in numerous proposals for tip-device concepts that cannot work as their proponents claim. We therefore take care in the following discussion to develop a correct understanding of the vortex wake and its role and to point out where some of the erroneous concepts went wrong.

The vortex wake starts as a vortex sheet shed from the trailing edge of the wing as a byproduct of producing the flow pattern shown in Figure 3.1. To understand the origin of the vortex sheet, look at the velocity vectors immediately above and below the wing in Figure 3.1. Note that the vertical components of these velocities are the same above and below the wing, but that the horizontal (spanwise) components undergo a "jump," from the outboard direction below the wing to the inboard direction above the wing. It is this jump in the spanwise velocity component that

constitutes the vortex sheet that ends up streaming back from the wing trailing edge. The vortex sheet is a necessary part of the flowfield because the conservation laws of fluid mechanics dictate that the wing cannot produce the general flow pattern of Figure 3.1 without also producing the jump in spanwise velocity. On an intuitive level, the spanwise-velocity jump can be understood as being a result of the tendency of air to flow away from the high pressure under the wing toward the low pressure above the wing. The wing itself presents an obstacle to this motion and deflects it in the spanwise direction.

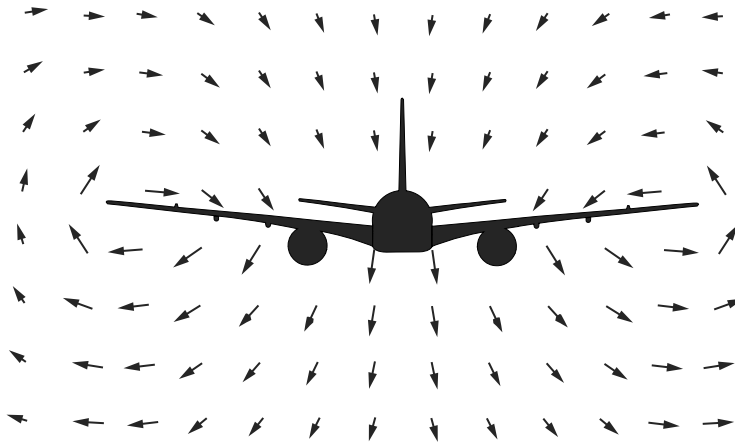

Figure 3.1. Velocities in a crossflow plane behind a lifting wing

The development of the vortex sheet after it leaves the trailing edge is illustrated in Figure 3.2. Within the first couple of wingspans downstream, the sheet generally rolls up toward its outer edges to form two distinct vortex cores. (This is the general pattern for a wing in the “clean” condition, flaps-up. The flaps-down pattern is more complicated, with cores forming behind flap edges as well behind the wingtips.) Although the vortex cores are distinct, they are not as concentrated as they are sometimes portrayed, since a considerable amount of air that was initially non-vortical is entrained between the “coils” of the sheet during rollup.

In Figure 3.2 the vortex sheet is illustrated as having essentially zero thickness, and the idealized theories model it that way mathematically. In the real world the vortex sheet is a physical shear layer of finite thickness that has its origin in the turbulent boundary layers on the upper and lower surfaces of the wing and, like the boundary layers, it is filled with small-scale turbulent motions.

The vortex cores are often referred to as “wingtip vortices,” though this is a bit of a misnomer. While it is true that the cores line up fairly closely behind the wingtips, the term “wingtip vortices” implies that the wingtips are the sole sources of the vortices. Actually, as we saw in Figure 3.2, the vorticity that feeds into the cores generally comes from the entire span of the trailing edge, not just from the wingtips.

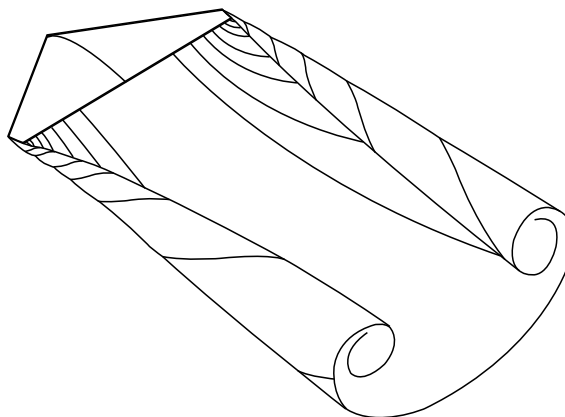

Figure 3.2. The vortex wake behind a lifting wing

Myths regarding the vortex wake, and resulting bad ideas for wingtip devices

With all of the above as background, we are ready to discuss two common misunderstandings regarding the nature and role of the vortex wake. I'll refer to these as the "compactness myth" and the "induction myth," and after defining them and explaining where they go wrong, I'll discuss some of the erroneous tip-device ideas that arise from them.

The compactness myth is simply the idea that the cores that contain all of the vorticity in the vortex wake after rollup are very compact. Illustrations that present misleading views of the vortex wake, such as those in Figure 3.3, are common, and they have helped to perpetuate the myth. The water-vapor condensation trails that can sometimes be seen streaming from flap edges or wingtips under humid conditions can also be misleading. These trails tend to mark only an inner portion of the core and give the impression that the core is more compact than it really is. The correct view, as we saw in Figure 3.2, is that the vortex rollup process produces cores that are relatively diffuse. The compactness myth is a simple misunderstanding that by itself wouldn't cause much harm, but when it is combined with the induction myth, the potential for serious mischief arises.

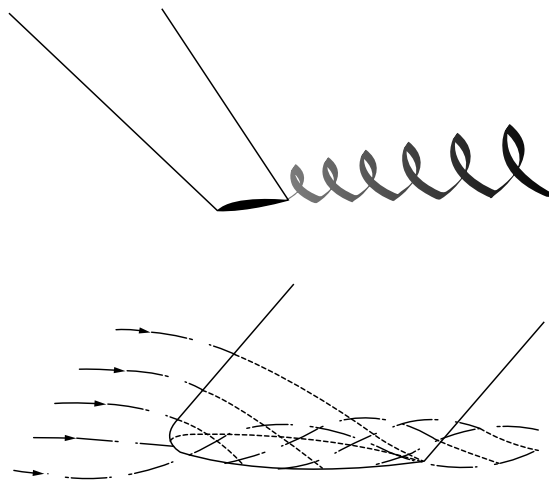

Figure 3.3. Misleading views of a compact "wingtip vortex"

The induction myth is more complicated and involves a serious misunderstanding of cause and effect. The trailing vortex sheet and the rolled-up vortex cores are often talked about as if they were the direct cause of the velocities everywhere else in the flowfield, and of induced drag, but this is misleading. It is true that in order for the large-scale flow pattern of Figure 3.1 to exist, there must be a vortex sheet shed from the trailing edge, but the vortex sheet is not a direct physical cause of the large-scale flow; it is more of a manifestation. This misunderstanding of correct cause and effect can be blamed on confusion engendered by the mathematics that is often used to analyze vortex phenomena.

The induction myth has its origin in the law of Biot and Savart, an equation that is used in theoretical treatments of physical phenomena in several fields. In classical electromagnetics, Biot-Savart determines the steady magnetic field "induced" by a known distribution of steady electric current. In fluid mechanics, Biot-Savart "determines" the velocity field, or at least part of it, when the vorticity distribution is known. Aerodynamicists have carelessly picked up the same terminology used

in electromagnetics when they say that the velocity is “induced” by the vorticity. The problem is that, when applied to fluid mechanics, this terminology seriously misrepresents the physics. In electromagnetics, “induction” represents a direct cause-and-effect relationship; that is, in the physical theory the magnetic field is assumed to be a direct result of the electric current, even though the two reside at different locations. There is no such “action at a distance” in the ordinary mechanics of fluids with no net electric charge. Fluid parcels in a flowfield respond only to forces transmitted by adjacent parcels, not to any remote “induction” effect. When applied to fluid mechanics, Biot-Savart is a just vector-calculus relation that has nothing to do with any direct physical cause and effect, and the term “induction” has no physical meaning. The vorticity in the flowfield is there as a result of the motion, not a cause, and the velocity at one location cannot be influenced directly by tampering locally with the vorticity somewhere else.

So what kind of mischief can result from the combined compactness and induction myths? The induction myth leads us to think of induced drag as being “caused” by the vortex wake, and thus to think that by doing something very local to change the flow in the core of the “tip vortex” we can have a large effect on the induced drag. To compound the error, the compactness myth leads us to think we can influence the induced drag by acting only on a very small part of the flow. This kind of thinking has spawned many erroneous ideas for novel wingtip devices. A common theme is to provide an inlet that scoops up the tip vortex itself, or some of the flow that would otherwise be entrained into the vortex, and to exhaust it straight back, presumably with its lateral motion and/or its vorticity removed. Some device ideas of this kind are illustrated in Figure 3.4. There is no credible evidence that any such device can provide a reduction in induced drag, beyond what can be explained as the result of an increase in physical span when the device is added.

Now we have seen why it is wrong to think that we can alter the global flow pattern of Figure 3.1 by tinkering with the tip vortex, without having to change the overall distribution of lift on the wing. But if Biot-Savart is correct, and a device like those shown in Figure 3.4 succeeds in swallowing part of the vortex and “straightening” it out, why isn’t the global flow pattern changed? The answer is that such devices cannot significantly change the total vorticity, which follows from the fact that the total vorticity is there as a result of the global flow pattern, not a cause. Even if a device eliminates the vorticity from the streamtube that passes through its inlet, compensating vorticity is generated and shed from the external surfaces of the device. Unless the overall distribution of lift on the wing is changed, the total vorticity and the global flow pattern are substantially unchanged.

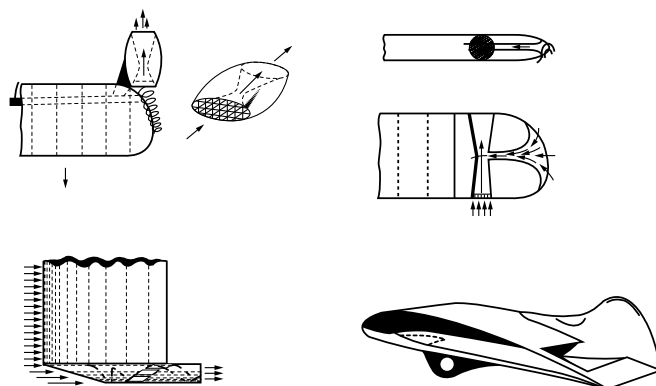

Figure 3.4. Some misguided tip-device ideas

Trefftz-plane theory and ideal induced drag

The theoretical framework that was established in the early 1900s for predicting induced drag is still in use today. “Trefftz-plane theory” is applicable to both planar and nonplanar lifting systems that can have one or more lifting surfaces. The theory takes the spanwise distribution of lift to be known and determines the induced drag either locally in terms of the backward tilt of the lift vector distributed along each lifting surface, or globally in terms of the total kinetic energy in a crossflow plane (the Trefftz plane) far downstream. The local determination defines both the distribution of induced drag along the surfaces and the total, while the global determination defines only the total. The total induced drag determined either way is the same. The flowfield velocities that are used in calculating the drag do not come from solving the equations of motion throughout the flowfield, but are inferred from an idealized model of the vortex wake, through the Biot-Savart law. The theory thus depends on inferring velocity from vorticity, which is justified mathematically, but obscures the physical cause-and-effect relationships. As a result, the physical understanding provided by the theory is not all that we might hope for. While the theory makes very clear the relationship between the downwash distribution and the distribution of drag, it does not provide any intuitive physical understanding as to why a particular lift distribution produces a particular downwash distribution. Although the physical understanding it provides is minimal, Trefftz-plane theory is very valuable for its quantitative predictions, and we will depend heavily on these predictions in all our discussions of tip-device concepts.

Trefftz-plane theory does not take into account the rollup of the trailing vortex sheet, but this has been found to be justified for wings of moderate-to-high-aspect ratio typical of transport airplanes. Given this idealized model for the behavior of the vortex wakes, the theory predicts that the total induced drag depends only on the spanwise distribution of lift and on the shape of the wing as seen in rear view, the so-called “Trefftz-plane view” comprising the span and the dihedral angle of the main wing, and the configuration of winglets or other nonplanar tip additions. Thus for a given spanwise distribution of lift, the total induced drag is independent of the fore-and-aft disposition, including the sweep, of the parts of the lifting system. Fore and aft disposition affects the spanwise distribution of induced drag but not the total. Historically, the predictions of the theory have been found to agree reasonably well with drag measurements both in the wind tunnel and in flight.

Theoretical models that might in principle predict induced drag with higher fidelity than Trefftz-plane theory are available, but they are not that widely used when the objective is to study induced drag. Computational Fluid Dynamics (CFD) methods based on Euler or Navier-Stokes equations predict the entire flowfield in detail, including the rollup of the vortex wake. However, flow solutions provided by these methods present us with the same problem we encountered with the real flow; that is, how do we define what part of the total drag is induced drag? It is telling that when users of high-fidelity CFD codes want a separate number for the induced drag predicted by their solutions, they generally have no choice but to plug their calculated lift distributions into Trefftz-plane theory.

So Trefftz-plane theory is our method of choice for predicting induced drag and comparing the drag-reduction effectiveness of different tip-device configurations. For comparisons between configurations to be fair, the configurations must be comparably optimized. At the level of Trefftz-plane theory, once the Trefftz-plane

geometry of a configuration has been fixed, the only thing left to optimize is the spanwise distribution of lift, hereafter referred to as the “spanload.” Trefftz-plane theory can be used to calculate “ideal” spanloads that provide the “ideal” (minimum) induced drag for a given Trefftz-plane configuration and a given total lift.

The well-known elliptic spanload is “ideal” for a planar (flat) wing. For nonplanar configurations, the ideal spanload is not generally elliptic, but it is easily calculated for a given geometry. With a vertical winglet added, for example, the ideal spanload shows less lift inboard and more lift outboard, relative to elliptic, with a certain, optimum distribution on the winglet itself, as shown in Figure 3.5. (Note that “lift” in this context refers to the aerodynamic force perpendicular to the wing locally, which in the case of the vertical winglet is a horizontal force inward.) Relative to these “ideal” spanloads, the spanloads used on real wings are usually modified somewhat to reduce bending loads and allow a lighter wing structure, at the expense of a slight increase in drag. The presence a fuselage and wing-mounted engines also tends to alter the spanload on real wings.

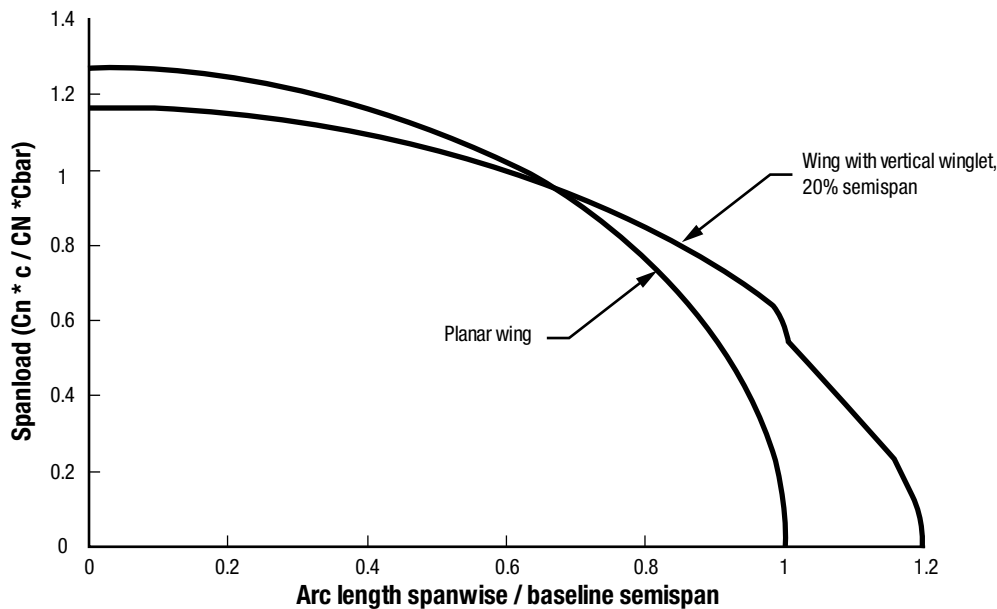

Figure 3.5. Ideal spanloads for a planar wing and a wing with a vertical winglet

The facts of life regarding induced drag and induced-drag reduction

We have seen that induced drag is a result of large-scale air motion produced by the lifting system. This motion is not physically “induced” by the vortex wake, but is a response to the lift force and depends on the overall lift distribution. When we try to go beyond this on an intuitive level, we are limited to very general observations, such as that increasing the span of a wing generally reduces induced drag. For anything more specific, especially regarding any device other than a simple span extension, we must rely on quantitative predictions, usually from Trefftz-plane theory. Unfortunately, the theory does not generally provide for a simple intuitive understanding of how the details of a particular configuration or lift distribution will affect the drag.

Based on our general appreciation of the physics, we can anticipate that drag-reduction devices need to be fairly large as viewed in the Trefftz plane, since any significant reduction in induced drag requires changing the global flowfield associated with the lift, so as to reduce its total kinetic energy. We know that we can't do this just by tinkering with the "tip vortex" and thus that having a significant effect on the drag requires a significant change in the way the lift is distributed spatially. If our starting point is a wing on which the lift is already advantageously distributed, the only way to improve will be to provide a significant increase in the horizontal span or to introduce a nonplanar element that has a similar effect. The quantitative theory tells us that the effect on drag will be roughly proportional to the horizontal and/or vertical span of the device and that a small device can therefore produce at most a small drag reduction.

There is a common misunderstanding that a wingtip device reduces drag by producing thrust on the surfaces of the device itself. For example, there is the popular explanation that likens a winglet to a sailboat beating into the wind, usually accompanied by a diagram showing the lift vector on the winglet being tilted forward by the strong "sidewash" directed inboard above the wingtip. This line of thinking is wrongly based on the flowfield that would be there in the absence of the winglet. The real flowfield is altered considerably if the winglet is properly loaded. When a wing and vertical winglet are unswept and are carrying their ideal spanload, the winglet cancels all of the sidewash and locally feels no induced thrust or drag. In this case all of the drag reduction due to the winglet is felt on the horizontal wing. If the wing is swept aft, some of the drag reduction will be felt as thrust on the winglet, but the wing is still where most of the reduction is felt, and the sailboat analogy is at best a misleading explanation.

Trefftz-plane theory tells us that we can reduce the ideal induced drag by increasing the vertical height of the lifting system, as well as by increasing the horizontal span. A vertical fin or winglet that adds vertical height to the system will reduce the ideal induced drag if it is placed anywhere along the span of the wing off of the airplane center plane, but it is most effective by far when it is placed at the station of maximum span; that is, at the tip. This is one example of the more general problem of minimizing the ideal induced drag of a lifting system with given maximum horizontal span and vertical height; that is, system that must fit within a given rectangular box in the Trefftz plane. The lowest-drag configuration is the box wing, which has lifting surfaces along all four sides of the box. Next lowest are configurations that don't reach all the sides but do reach all the corners. Figure 3.6 illustrates a series of such configurations, in order from lowest ideal induced drag to highest. Note that any retreat from the corners of the box (e.g., a "blending" region in the junction between a winglet and the wing) increases ideal induced drag, but that there may be compensating advantages such as avoiding the viscous-drag penalty associated with sharp-cornered intersections.

Ideal-induced-drag theory is useful for guidance as to how to achieve a large reduction in induced drag, but the benefits implied by the levels of drag reduction it predicts are not generally achievable in practice. First, the induced-drag reduction that can actually be achieved in most applications typically falls significantly short of ideal. In addition, the actual induced-drag reduction is always offset by other factors that detract from the net benefit to the airplane.

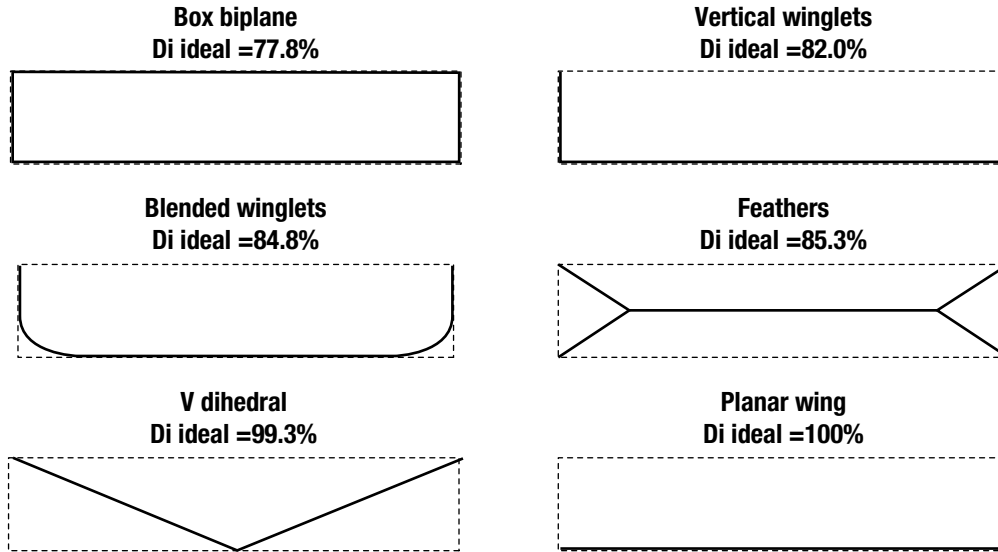

Figure 3.6. Lifting-surface configurations constrained to fit within a rectangular box in the Trefftz plane, shown in order from the lowest ideal induced drag to the highest

Two factors can contribute to the shortfall in induced-drag reduction relative to ideal. The first, as has already been mentioned, is that spanloads of real wings are usually compromised to reduce bending loads and save structural weight, carrying more load inboard and less load outboard than the ideal spanload. Because of the reduced load outboard, a tip device of a given size has less leverage in reducing induced drag than it would in the case of ideal loading. If the tip device is to be retrofitted to an existing wing, a second factor generally comes into play, and that is that, because of the twist distribution of the existing wing, the best spanload that can be achieved with the device installed will be further from ideal than the load on the original wing was.

The addition of a wingtip device generally adds wetted surface area and thereby increases viscous drag, and there may also be junction flows or areas with unfavorable pressure distributions that further increase the viscous drag. The redistribution of the spanload that the device produces can change the shock drag on the rest of the wing, but this effect can go in either direction and is usually not large. In any case, the induced-drag reduction is nearly always partly offset by a net increase in the other drag components. We will look at one quantitative example in the section on API winglets for the 737NG.

Any practical device that reduces induced drag generally increases bending moments on the entire wing at the cruise condition and at the critical flight conditions that determine the design of the wing structure. The addition of a wingtip device, therefore, usually requires beefing up the wing structure, which adds weight, over and above the weight of the device itself, and subtracts from the net benefit of the device. This trade between drag reduction and weight increase is discussed further in the section on device concepts. When a tip device is included in the design of an all-new wing, this structural-weight penalty must generally be paid in full. On an existing airplane, flight testing will sometimes have established that the wing has excess structural margin that can be "used up" by the addition of a tip device. The presence of an existing excess structural margin can reduce or even eliminate the required beefing up of the existing structure.

Milestones in the development of theory and practice

Lanchester, the British aeronautical pioneer, had developed a qualitative understanding of the 3D flow around a lifting wing, including the vortex wake, by 1907 (reference 2). A quantitative understanding of induced drag was first provided by the Trefftz-plane/lifting-line theory, developed by Prandtl in 1910 (reference 3) and elaborated by several others in the following years. Even now, well into the era of CFD, our conceptual understanding of induced drag depends almost entirely on this early theoretical work. The conceptual touchstones include:

- The elliptic ideal spanload (for minimum induced drag) and the simple formula for predicting the ideal induced drag of a planar wing.
- The prediction that multiple and/or nonplanar lifting surfaces, including endplates, could have lower induced drag than a simple planar wing of the same maximum horizontal span.
- Munk's stagger theorem (reference 3), and the general prediction that, for a given Trefftz-plane geometry and spanload, the induced drag is independent of the fore-and-aft disposition of the lifting surfaces.

We've already discussed ideal-induced-drag theory and pointed out that it provides a method by which the potential induced-drag-reduction effectiveness of various lifting-surface geometries can be compared fairly. One of the best-known examples of such studies is by Cone (reference 4), in which he used a physical analog apparatus based on a rheoelectric analogy to "solve" the ideal-induced-drag optimization problem and compare many different Trefftz-plane shapes, a sampling of which is shown in Figure 3.7. He found that practically any nonplanar shape that adds vertical height near the tip could reduce ideal induced drag. Results like these provided the basis for the development of many of the tip-device concepts discussed in the next section.

Figure 3.7. Some lifting-surface configurations (Trefftz-plane shapes) investigated by Cone (reference 4)

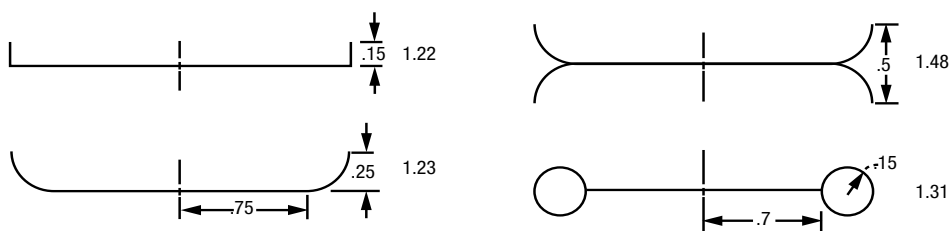

The realization that nonplanar lifting systems could generally reduce drag did not immediately lead to successful applications, however. For example, simple flat endplates were tried numerous times in the years after it was first predicted that end plates would reduce induced drag, but in practice they never produced a net drag benefit. Their induced-drag reduction tended to fall short of ideal, and it was always more than offset by the increase in viscous drag due to added wetted area and corner flows. I think it is likely that the failure for so many years to find a better configuration than the flat endplate can be blamed on an "endplate paradigm" based on a particular way of looking at the Trefftz-plane theory. The reasoning leading to the endplate paradigm is as follows. In the limit as the vertical span of an endplate becomes large, the ideal spanload on the horizontal wing becomes uniform. One way to achieve this situation is to have 2D flow over the wing, enforced by endplates that are flat and large in chord as well as span. The resulting paradigm is that an endplate should always be flat and have a large chord.

What the endplate paradigm fails to recognize is that in order to realize the ideal induced drag of an endplated configuration, only the spanwise distribution of load on the endplate needs to be ideal, and it doesn't matter how the load is distributed longitudinally. A vertical tip device of small chord can achieve the same induced-drag reduction as a large endplate of the same span just by carrying the right spanload. Whitcomb (reference 1) seems to have been the first to recognize this and to realize that an effective endplate is just another part of the lifting system; that is, a lifting surface that should be carrying a spanload close to ideal, just like the rest of the wing. Of course to keep the viscous drag of a lifting surface low, the surface should have an efficient aerodynamic cross-section; that is, an airfoil, and the chord of the surface should be sized consistent with the efficient load carrying capacity of the section. This is simply good aerodynamic design practice of the kind that has always been applied to wings, and Whitcomb's contribution was to apply it to what had formerly been seen as just an endplate. While the direct result of Whitcomb's work was the classic near-vertical winglet, his general idea of applying good design practice to keep the profile drag low has also contributed to the development of concepts other than the winglet.

The trade between drag reduction and structural weight was not addressed explicitly in most early work, but it began to attract attention with the development of the winglet. Whitcomb's work on winglets suggested that for a given increase in bending moment on the inboard wing, a near-vertical winglet offers nearly twice as much drag reduction as a horizontal span extension. This suggestion was not based on theory, however, but on the results of wind-tunnel tests comparing configurations that were not comparably optimized. The first systematic theoretical investigation of the question was published by R.T. Jones in 1980 (reference 5). He used Trefftz-plane theory to calculate induced drag, and integrated bending moment as a rough indicator of likely structural weight. Starting with a baseline elliptically loaded wing of a given span, he added horizontal and vertical tip extensions of varying length. For each device length, he optimized the spanload to minimize induced drag, subject to the constraint that the integrated bending moment, or "structural weight," was the same as that of the baseline. As the size of the extensions increased, the spanloads had to become increasingly "non-ideal" in order to meet the constraint, and yet drag was still reduced. Repeating the calculations with root bending moment instead of integrated bending moment as the constraint produced essentially the same results. The calculations indicate that horizontal span extensions and vertical winglets offer essentially the same maximum induced-drag reduction when the spanloads are constrained so that there is no increase in "structural weight." They also indicate that to achieve a given level of drag reduction, a vertical winglet must be nearly twice as large as a horizontal span extension. In the next section we'll see results of more-recent, higher-fidelity calculations that support similar conclusions.

4. Wingtip Device Concepts

Whitcomb's breaking of the "endplate paradigm" has led to the development of a variety of wingtip devices that can be effective in reducing total drag, some of which were shown in Figure 1.1. It is assumed from here on that Whitcomb's basic idea of applying good aerodynamic design practice will be adhered to in executing any of the concepts. We'll start our discussion of this assortment of competing concepts by listing the basic strategies that are used in various combinations by the different devices.

Basic strategies for practical tip devices

Increasing horizontal span (straight and tapered tip extensions)

Going nonplanar:

- Bending (winglets).
- Bending with blending (blended winglets reduced wetted area and junction drag).
- Splitting (split winglets and feathers: vertical height with less wetted area penalty).
- Splitting and rejoining (spiroids).

Part-chord devices (less chord than the baseline wingtip):

- Trapezoidal baseline tip often has more chord than needed to carry spanload.

Pronounced tapering:

- Reduces wetted area and critical structural loads.
- Applicable to all tip-device concepts.

Additional sweep (e.g., raked tips):

- Increases aeroelastic washout and reduces wing weight.
- Not very effective for a vertical winglet.

PD-level trades affecting device performance

In this section we'll compare the potential performance advantages of various tip-device configurations. In order for the comparisons to be fair, all of the devices must be comparably optimized. We've seen that much of the early theoretical work concentrated on induced drag only, and that minimization of induced drag alone defines the "ideal" induced drag and the "ideal" spanload. Ideal-induced-drag theory is useful for initial screening of concepts and for understanding basic trends, but it is not a realistic optimization target for real-world tip devices. The spanload of a real transport-airplane wing, with or without a tip device, is not generally optimized for minimum induced drag, but instead is optimized for a favorable trade between total drag and structural weight. This is still spanload optimization, just to a bottom-line performance objective such as fuel-burn or maximum range, rather than to an esoteric aerodynamic target.

The usual procedure in design studies is to define the general configuration of a candidate tip device in terms of its planform and dihedral angle(s) and then to estimate its performance through analysis. A step that should always be included in this process is the optimization of the spanload. When the planforms and airfoil cross-sections of the wing and the tip device are given, the spanload is controlled by the twist distribution. If both the wing and the tip device are all-new, the twist distribution of the entire system is open to optimization. In derivative or retrofit applications, the twist distribution of the existing wing is generally fixed, and the

twist distribution of only the tip device itself can be optimized. If the twist distribution of the existing wing was optimized for operation without a tip device, the benefit available from the addition of the tip device will usually be substantially less than it would have been if the wing could have been re-optimized. In the discussion that follows, it is assumed that the twist distribution of each candidate tip device has been optimized to an appropriate bottom-line performance objective. For real-world design studies, computational tools are available that can perform this optimization to different levels of physical fidelity, depending on the purpose of the study.

Let's start with the effects of device size, a trade that affects all devices in essentially the same way. Figure 4.1 shows figurative trends in four performance measures as functions of device size for a generic tip device, assuming that the baseline airplane with no device has no excess structural margin, and that for all sizes the device has been optimized for some bottom-line measure of airplane performance, such as fuel burn. Note that induced drag cannot be reduced below zero, no matter how large the device is made, so that the percentage drag reduction must eventually show a diminishing rate of return with increasing size. For reasonable device sizes, the percentage weight increase tends to be roughly linear with size. Because of the weight increase, the percentage fuel-burn reduction is usually less than the percentage drag reduction. The increase in maximum range depends on what is limiting the range. If the range is limited by a fixed maximum take-off gross weight (TOGW), the weight increase due to the device will subtract directly from the fuel that can be carried, and the increase in range may be very small and may disappear for devices above a certain size. If the takeoff gross weight is limited by second-segment climb, and the tip device improves take-off L/D, adding the device may increase the fuel that can be carried, the percentage range increase may be greater than the percentage fuel-burn reduction, and larger devices may be favored. Thus we see that the optimum device size depends on what performance objective is sought.

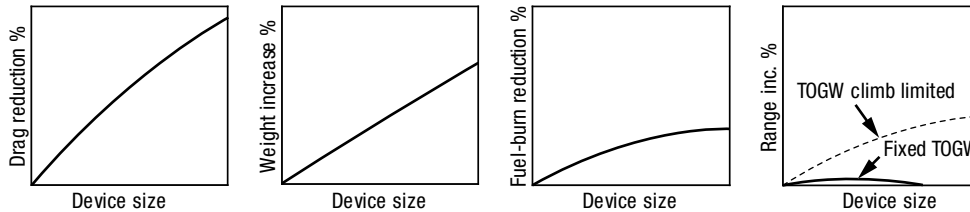

Figure 4.1 Effects of device size on performance for a generic wingtip device, assuming no excess structural margin in baseline wing

Now let's look at the comparative advantages of horizontal span and vertical height. Earlier we mentioned that Whitcomb's work on winglets (reference 1) suggested a rule of thumb to the effect that for a given increase in bending moment on the inboard wing, a near-vertical winglet offers nearly twice as much drag reduction as a horizontal span extension. This rule of thumb has not been borne out by studies since then. R.T. Jones's 1980 paper (reference 5) indicated that horizontal span extensions and vertical winglets offer essentially the same maximum induced-drag reduction when the impact on "structural weight" due to bending loads is kept the same. More recent studies, of which we'll see an example below, have reached the same conclusion. Figure 4.2 shows figurative trends in four performance measures, as functions of device size as in Figure 4.1, but now showing both horizontal span extensions and vertical winglets. For a given device size, a horizontal extension is nearly twice as powerful as a vertical one, both in terms of drag reduction and weight

increase. Comparing devices sized to produce the same weight increase, that is, a horizontal span extension compared with a vertical winglet nearly twice as large, the drag reduction is essentially the same.

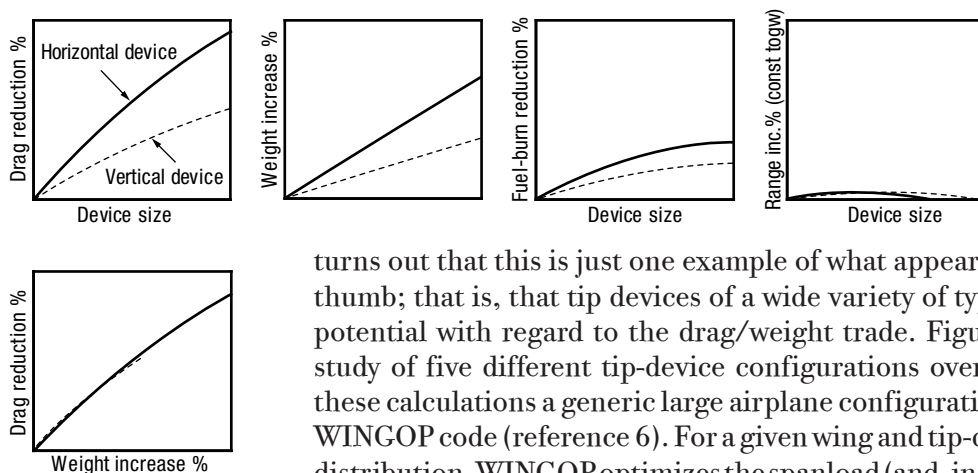

Figure 4.2. Breakdown of the drag reduction of the API blended winglets on 737NG

So in terms of the trade between drag reduction and weight increase, horizontal span extensions and vertical winglets have practically the same performance potential. It turns out that this is just one example of what appears to be a more-general rule of thumb; that is, that tip devices of a wide variety of types seem to have very similar potential with regard to the drag/weight trade. Figure 4.3 shows the results of a study of five different tip-device configurations over a range of device sizes. For these calculations a generic large airplane configuration was modeled in the Boeing WINGOP code (reference 6). For a given wing and tip-device planform and thickness distribution, WINGOP optimizes the spanload (and, in effect, the lifting-surface twist distribution), taking induced drag, profile drag, and wing structural weight into account. In this study it was assumed that the twist of the entire wing could be optimized for each candidate tip device, which is what would be assumed in the design of an all-new wing, and the baseline wing was assumed to have no excess structural margin. Since all of the spanloads were comparably optimized, the comparisons between the different device configurations are as fair as they can be, given WINGOP's relatively simple level of physical modeling. The result of this study is that the drag-versus-weight effectiveness of all of these device types falls within a surprisingly narrow band. At this fundamental level, the differences between these different device configurations are small and could easily be overshadowed by differences due to detailed design execution.

Figure 4.3 illustrates the trends that apply when the twist distribution of the entire lifting system, including the baseline wing, is free to be optimized for each tip device, as it would be with an all-new wing. What happens if we add these tip devices to an existing wing with a twist distribution optimized for operation without a device, and only the twist distributions of the devices themselves can be optimized? When the calculations of Figure 4.3 were repeated with this assumption, qualitative trends remained the same, but there were quantitative differences. The relative performances of the different devices were essentially the same as before, but in general about 15 percent less drag reduction was available for a given weight increase, and for a device to have the same impact on drag as before, it would have to be about 60 percent larger.

Of the configurations shown in Figure 4.3, the best by a small margin is the tip feathers. This seems to reflect a small general advantage for devices in which the lifting surface splits into two branches. In general, splitting allows a given level of induced-drag reduction to be achieved with less additional wetted area than a nonsplit configuration would require. For a feather configuration with a small included angle such as the one shown in Figure 4.3, the wetted-area increase is only a little more than that of a horizontal span extension of the same projected span, but the induced-drag reduction is considerably greater. Of course, the weight increase is also considerably greater, so that the advantage in terms of drag versus weight is

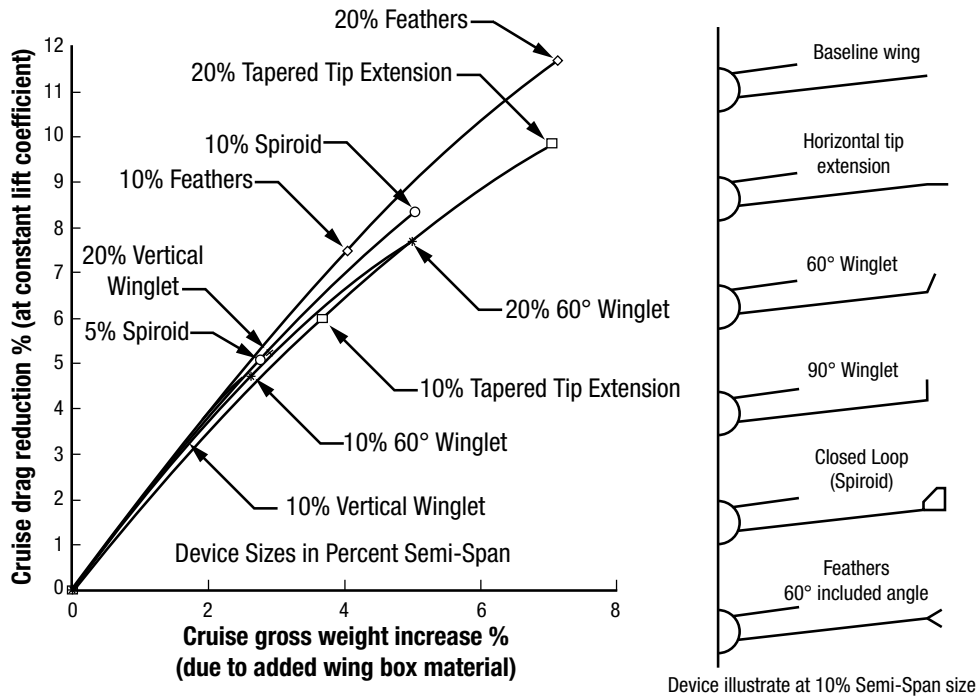

Figure 4.3. Comparison of CFD-based drag prediction and flight test for API blended winglets on 737NG

not large. If we increase the included angle between the feathers to 180 degrees, we have equally split vertical winglets. Comparing this with a simple vertical winglet of the same total height, we find that the ideal spanloads for both are about the same at the junction location. In the case of the split winglets, this load splits evenly between the two branches, so that if we size the chord of the device according to the load carried, the split winglets need only half as much chord as the single winglet. The split winglets produce about 90 percent of the induced-drag reduction of the single winglet with only about half as much additional wetted area. A drawback to split winglets in practice is that the span of the lower winglet is often limited by ground clearance.

Other considerations

We have seen that in the choice between winglets, horizontal span extensions, and other tip-device configurations, there is no clear-cut favorite for all applications. In terms of the basic physics, the benefits they offer tend to be comparable. Which choice is favored for a particular application depends on the details of the baseline airplane and on the mission objective, and the difference between the two choices is usually not large. For example, during the development of the 767-400, a business-case study indicated that a span extension in the form of a raked tip was superior to a winglet. Also, for all-new wings, most recent design studies have indicated that raked tips of the type used on the 767-400 are slightly superior to winglets. For derivative airplanes or retrofit to existing airplanes, the benefit of tip devices of all types depends on the lift distribution of the baseline wing. If the baseline outboard wing is relatively lightly loaded, as on the 747-200, the potential benefit of tip devices can be greatly reduced. The drag reduction of the tip extension-plus-winglet on the 747-400 is significantly less than it would have been had the baseline (747-200) outboard wing been more heavily loaded, and adding a larger tip device to the 747-400 would be unlikely to yield significant further improvement.

For retrofit applications such as the 737NG and BBJ, the required structural modifications to the existing wing inboard of the tip device depend strongly on the amount of structural margin available in the baseline wing. For the API winglet on the BBJ, the baseline structural margin was such that only minimal changes were required. Also, although winglets and raked tip extensions have roughly equal impacts on bending loads for a given amount of drag reduction, winglets have less impact on shear loads. Beefing up shear webs does not generally add much weight, but it is expensive in retrofit applications, and this is a factor that will favor winglets over raked tips in some cases.

5. API Winglets on the 737NG Family

The blended-winglet configuration developed by API for the 737NG family is shown in Figure 5.1. The winglets span nominally 8 feet and are canted outward at an angle of 15 degrees from vertical on the ground and about 6 degrees in one-g



Figure 5.1. API blended winglet configuration for the 737NG family

flight. The junction between the wing and winglet is significantly rounded (“blended”), a feature that sacrifices some of the potential induced-drag reduction in return for less viscous drag and less need to tailor the airfoil sections locally in the junction region. There is no discontinuous change in chord at the junction as there would be with a conventional part-chord winglet, but within the blending region, the chord decreases rapidly and smoothly, so that the chord distribution from there out is similar to that of a part-chord winglet.

As we mentioned in the previous section, the general part-chord strategy for tip devices is a way of integrating an outboard chord distribution consistent with the desired spanload with an existing trapezoidal wing that has more chord than it needs at the tip.

Table 5.1 compares estimates and measurements of the reductions in induced drag and total drag for cruise at Mach 0.78 and a lift coefficient of 0.51. Note that ideal induced drag based on the Trefftz-plane configuration of the installation overestimates the induced-drag reduction, compared to the CFD estimate based on the actual wing shape. This shortfall relative to ideal is due to constraints imposed by the planforms of the wing and winglets and the twist distribution of the existing wing. According to the CFD estimate, the reduction in total drag is less than the reduction in induced drag, primarily because of the increase in wetted area. The CFD estimate and Boeing flight test results agree reasonably well on the total drag reduction.

The blended winglet assemblies themselves weigh 300 pounds per pair. Beefing up the wing structure added 100 pounds. If the original wing had had no excess structural margin, it is estimated that 600 pounds of beefing up would have been required.

Component	Drag reduction, % of total AP
Ideal based on Trefftz-plane configuration only: Induced drag	4.8
High-fidelity CFD (TRANAIR) based on actual wing shape with estimated 1-g aeroelastic deflections: Induced drag Total drag	3.1 2.8
Inferred from average of Boeing flight-test measurements: Total drag	3.2

Table 5.1 Estimated and measured reductions in induced drag and total drag at Mach 0.78 and a lift coefficient of 0.51 due to API winglets on 737-800, relative to the airplane without winglets.

6. Conclusions and Observations

When evaluating the benefits of wingtip devices it is not sufficient to look at just the reduction in drag, or the improvement in L/D or tops-down efficiency. The real measure of the performance improvement is in bottom-line performance objectives such as fuel-burn or maximum range, taking into account the weight penalty of the installation, as well as the drag reduction. Which device configuration and device size turn out to be optimum will depend on which performance objective is sought and on the design details of the baseline airplane.

A reduction in induced drag is the major positive factor contributing to any net benefit for a tip device. Unfortunately, there are in common circulation some misunderstandings of induced drag and induced-drag reduction, mostly stemming from mistaken ideas regarding the role of the vortex wake. To evaluate tip-device candidates correctly and to understand what is likely to work and what isn't, we must keep the correct physics in mind. The classical Trefftz-plane theory isn't perfect, but it is always a good place to start. Any tip-device performance claim that is out of line with Trefftz-plane theory is probably wrong.

Ideal-induced-drag theory (the theory of minimum induced drag for a given total lift, based on Trefftz-plane theory) is useful conceptually for understanding the relative drag-reduction potentials of different device configurations, but it is a poor guide to the net level of benefit that can be achieved. The actual induced-drag reduction is always significantly less than ideal, substantially so in retrofit and derivative applications, and increases in viscous drag and weight generally offset some of the induced-drag reduction. The structural-weight impact is always a major player in the design trades. The magnitudes of all of the offsetting factors depend strongly on the design details of the baseline airplane and the device.

A variety of tip-device configurations have been identified as potentially beneficial, and analyses that take all the relevant factors into account have not found any one configuration to have any pronounced general advantage over the others. Inherent differences in optimized net benefit are small, on the same order as differences that could arise due to detailed design execution. This may be one of few places on an airplane configuration where a design decision can, at least sometimes, be based on styling without a major impact on performance. A raked tip extension will often be the most cost-effective option, unless it exceeds a gate-clearance limit or requires expensive beefing up of the shear webs of an existing wing.

References

1. Whitcomb, R. T., A Design Approach and Selected Wind-Tunnel Results at High Subsonic Speeds for Wing-Tip Mounted Winglets, NASA-TN-D-8260, 1976
2. Lanchester, F. W., Aerodynamics, Constable, London, 1907
- 3 Prandtl, L. and Tietjens, , O. G., Applied Hydro- and Aeor-Mechanics, McGraw Hill, New York, 1934
4. Cone, C. D., The Theory of Induced Lift and Minimum Induced Drag of Nonplanar Lifting Systems, NASA Technical Report R-139, 1962
5. Jones, R. T. and Lasinski, T., Effect of Winglets on the Induced Drag of Ideal Wing Shapes, NASA TM-81230, 1980
6. Craig, A. P. and McLean, J. D., Spanload Optimization for Strength Designed Lifting Surfaces, AIAA Paper 88-2512, 1988